

Wirewound Rheostat/Potentiometer



FEATURES

- 12 W at 25 °C
- CCTU 05-03B (PA9)
- Vitreous style
- Compliant to RoHS directive 2002/95/EC



DIMENSIONS in millimeters

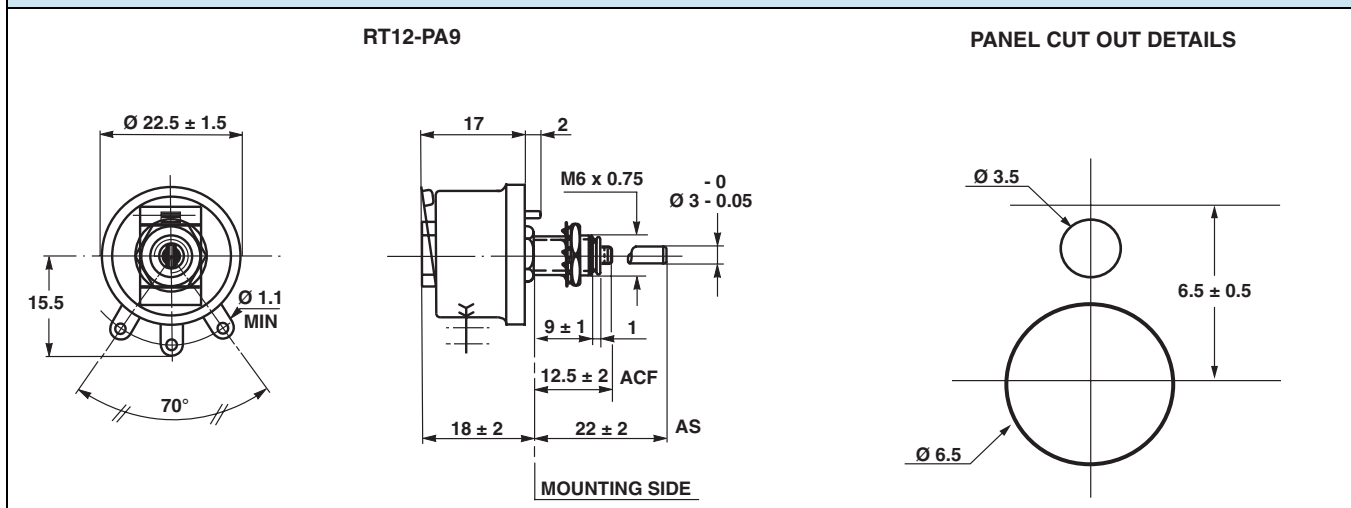

MECHANICAL SPECIFICATIONS

Mechanical Protection	Vitreous
Mechanical Travel	290° + 15° - 10°
Operating Torque	1 Ncm to 10 Ncm
End Stop Torque	25 Ncm
Unit Weight	18.3 g

LOCKING DEVICE

The spindle locking device can be fitted only to special units equipped with a slotted bushing.
Order reference: B

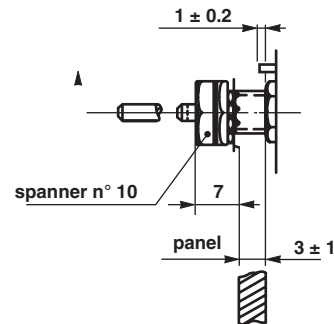

ENVIRONMENTAL SPECIFICATIONS

Temperature Range	- 55 °C + 320 °C
Climatic Category	CCTU 454 CEI 55/200/56

ELECTRICAL SPECIFICATIONS

Ohmic Range	1 Ω to 2.2 kΩ
Tolerance Standard	± 10 %
Power Rating	12 W at 25 °C
Variation Law	Linear
Limiting Element Voltage	300 V
Dielectric Strength	1000 V _{RMS}
Insulation Resistance	10 ³ MΩ (500 V _{CC})

SPINDLES

Ø mm	DISTANCE TO MOUNTING PLATE mm	SCREW DRIVER SLOT	CODE
3	12.5	With	ACF
3	22	Without	AS

Note

- For any special requirement on request: spindle flats, etc. Please supply detailed drawing.

PARTICULAR CHARACTERISTICS		
NOMINAL RESISTANCE Ω	MAX. SERVICE VOLTAGE V	MAX. CURRENT THROUGH WIPER mA
1	3.46	3460
1.5	4.24	2830
2.2	5.14	2340
3.3	6.29	1910
4.7	7.51	1600
6.8	9.03	1330
10	11	1100
15	13.4	900
22	16.3	740
33	19.9	603
47	23.7	505
68	28.6	420
100	34.6	346
150	42.4	283
220	51.4	234
330	62.9	191
470	75.1	160
680	90.3	133
1K	110	110
1.5K	134	90
2.2K	163	74

COMMAND KNOB: 20JF (OPTION)

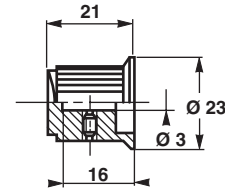

DIAL: CG45 (OPTION)

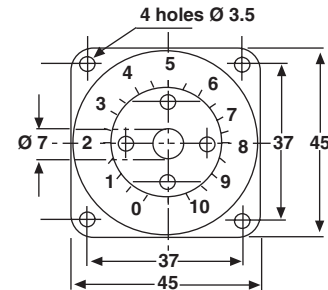

MARKING

Vishay Sfernice trademark, series, style, ohmic value (in Ω or $k\Omega$), tolerance (in %), maximum current in A, manufacturing date

ORDERING INFORMATION						
RT	012	AS	1501	K	B	XXX
MODEL	STYLE	SPINDLE	OHMIC VALUE	TOLERANCE	PACKAGING	SPECIAL DESIGN

GLOBAL PART NUMBER INFORMATION												
R	T	0	1	2	A	S	4	7	0	1	K	B
GLOBAL MODEL	SIZE	LOCKING DEVICE (OPT.)	WINDING (OPT.)	COMMAND SHAFT	OHMIC VALUE	TOLERANCE	PACKAGING	SPECIAL				
RT	012	D	BXXX or BXXXX As applicable xxx(x) = Internal number	AS = Standard (Diam: 3 mm) ACF	The three first digits are significant figures and the last digit specifies the number of zeros to follow. R designates decimal point. 2002 = 20 k Ω 4701 = 4.7 k Ω 48R0 = 48 Ω 0R01 = 0.01 Ω	J = 5 % K = 10 %	B = Bulk BO10 No standard packaging: N = Bulk, qty. open	As applicable Ex = DXxx				



Disclaimer

All product specifications and data are subject to change without notice.

Vishay Intertechnology, Inc., its affiliates, agents, and employees, and all persons acting on its or their behalf (collectively, "Vishay"), disclaim any and all liability for any errors, inaccuracies or incompleteness contained herein or in any other disclosure relating to any product.

Vishay disclaims any and all liability arising out of the use or application of any product described herein or of any information provided herein to the maximum extent permitted by law. The product specifications do not expand or otherwise modify Vishay's terms and conditions of purchase, including but not limited to the warranty expressed therein, which apply to these products.

No license, express or implied, by estoppel or otherwise, to any intellectual property rights is granted by this document or by any conduct of Vishay.

The products shown herein are not designed for use in medical, life-saving, or life-sustaining applications unless otherwise expressly indicated. Customers using or selling Vishay products not expressly indicated for use in such applications do so entirely at their own risk and agree to fully indemnify Vishay for any damages arising or resulting from such use or sale. Please contact authorized Vishay personnel to obtain written terms and conditions regarding products designed for such applications.

Product names and markings noted herein may be trademarks of their respective owners.